

# NOVATECH INSTRUMENTS

## INSTRUCTION MANUAL

### Model 409C, 171 MHz, 4-Channel Signal Generator



### Model 409C

#### Table of Contents

Section	Page	Contents
1	2	Description
2	2	Specifications
3	3	Hardware Installation
	5, 6 & 7	Tables 2, 3 & 4 Serial Commands
4	8	Operating Instructions
5	12	Theory of Operation
6	13	Performance Test
7	14	Calibration
8	14	Option /R
9 & 10	15	Option -AC & E
	16	Warranty

**NOTE:**

*This manual applies to Model 409C with firmware version 2.1 and higher.*

**1.0 DESCRIPTION**

**1.1** The Model 409C is a four-channel Direct Digital Synthesized (DDS) Signal Generator in a small table top case with serial control. The 409C provides four independent, phase-synchronous sine wave output signals, which can be set from 0.0 Hz (DC) to 171 MHz in 0.1 Hz steps.

**1.2** The 409C System Clock can be an internal TCXO oscillator or a user supplied external signal.

**1.3** A Table feature enables users to store frequency, phase, amplitude and dwell time. The 409C can then run through the table automatically or step through it on command from the serial port or from an external hardware trigger.

**1.4** A Frequency Sweep feature enables the user to generate automatically generated programmable sweeps .

**1.5** The –AC option provides two rear panel mounted SMA connectors that can also be used to trigger and synchronize 409C output updates using external hardware triggering.

**1.6** The /R option converts the external clock input to a 10MHz reference input. This option enables locking to and tracking an external 10MHz reference with no binary round-off errors. When this option is installed the accuracy and stability of the output are equal to those of the reference.

**2.0 SPECIFICATIONS**

**2.1 OUTPUTS**

**TYPES:** Four independently programmable, phase synchronous, sine wave outputs.

**IMPEDANCE:** 50Ω.

**RANGE:** 0.0 Hz to 171 MHz in 0.1 Hz steps (Sine out, int. clock).

**SINE AMPLITUDE:** Programmable from 0.000 to 1.000 Vpp into 50Ω (+4dBm).

**PHASE:** Programmable from 0 to 359.99 degrees.

**FLATNESS:** ±3dB from 1 kHz to 150 MHz referenced to amplitude at 35 MHz, full scale.

**2.2 TABLE**

Stores up to 14,250 rows containing frequency, phase, amplitude, row number and a dwell time in non-volatile memory. Each row can contain data for up to four output channels.

**2.3 CONTROL**

Output frequencies (32-bits), amplitudes (10-bits) and phases (14-bits) are controlled by sending commands from the USB serial port or by executing rows saved in the 409C table. All outputs and other settings can be saved in non-volatile memory.

**2.4 FREQUENCY ACCURACY AND STABILITY**

Accuracy: <±1.5ppm at 10 to 40°C. Stable to an additional ±1ppm per year, 18 to 28°C. (Internal Clock)

**2.5 EXTERNAL CLOCK IN**

**LEVEL:** 0.2 to 0.5Vrms sine or square wave. 50Ω.  
**FREQUENCY:** 10MHz to 125MHz with Clock set to External Reference (C e) or 1MHz to 500MHz with Clock set to direct input (C d).

**2.6 INTERNAL CLOCK LOCKED TO EXTERNAL 10MHZ (/R OPTION):**

External clock must be 10 MHz, ±5ppm. Automatically detected. Internal clock is locked to and tracks this value. Level must be 0.2 to 0.5 Vrms, sine or square wave, 50Ω..

**2.7 SPECTRAL PURITY**

(Typical, 50Ω load, Clock set to Internal (C I), Output set to full-scale)

Phase Noise: <-120dBc, 10 kHz offset, 10 MHz out.

Spurious:

<-60dBc below 10 MHz (typ. 300MHz span)

<-60dBc below 40 MHz

<-55dBc below 80 MHz

<-50dBc below 160 MHz

Harmonic:

<-65dBc below 1 MHz

<-55dBc below 20 MHz

<-45dBc below 80 MHz

<-35dBc below 160 MHz

(channel-channel isolation: <-60dBc)

## 2.8 POWER REQUIREMENTS

+5.25Vdc (+5.0 to +5.5V)@<750mA.

## 2.9 SIZE

39mm H, 107mm W, 172mm L, not including connectors.

## 2.10 CONNECTORS

BNC for Sine Outputs and External Clock Input. Barrel type 2.5mm center positive power receptacle for +5 volts power input. USB 2.0 Type B female & 14 pin header for logic I/O or Optional DB9.

## 2.11 LOGIC I/O (J8 AND -AC OPTION)

Voh >=2.4V and Vol <=0.4V when series terminated. Output Rise and fall times <100ns.

## 2.12 OPTIONS

**OPTION /R:** Rear mounted BNC requires external 10MHz reference clock input. The 409C internal clock is phase locked to and tracks the 10MHz input. (See Section 8.0)

**OPTION -AC:** Provides two rear panel SMA connectors and 470 ohm series resistors for IOUD and TS signal inputs.. (See Section 9.0)

**OPTION /RS232:** Replaces rear panel USB connector and J8 connector with DE9 connector. A USB to Serial Adapter is provided with this option. (See paragraph 3.4)

## 3.0 HARDWARE INSTALLATION

**3.1 Power Connection.** The input power is applied through a 2.5mm center-positive power connector on the rear panel. A solid green light on the front panel LED indicates power is on.

**3.2 Power Supply.** The quality of your power supply affects the performance of the 409C. The supply should be free of ripple and noise (<100mV). Even though extensive filtering is used internal to the 409C, a quiet and well regulated power supply will ensure optimum performance. The supplied AC-adaptor has been tested for proper operation.

**3.3 USB Serial Interface Installation.** The 409C is typically controlled from a computer with a USB port. In

this configuration the user computer needs to have the virtual COM port driver that is compatible with the USB port on the 409C. This driver is made by Silicon Labs and it is already installed on some computers. The Silicon Labs virtual COM port driver can be found at:

<https://www.silabs.com/developers/usb-to-uart-bridge-vcp-drivers>.

The Silicon Labs VCPdriver for Microsoft windows is included on the USB memory stick that comes with the 409C. To install this driver select the CP210xVCPInstaller... application that matches your computer and run it.

**3.4 /RS232 Option Installation.** For 409C models with the /RS232 option installed the 409C uses an RS232 serial port, instead of the standard USB port. The /RS232 option includes the XCHIP-X RS232 to USB adapter from FTDI. The virtual COM port driver for the XCHIP-X is already installed in many computers. If it is not installed then it can be downloaded at:

<https://ftdichip.com/drivers/vcp-drivers/>

Once the virtual COM port driver is installed you connect the 409C to your computer using the provided cable. The computer will then automatically create a virtual COM port.

**3.5 Virtual COM Port Settings.** The USB and RS232 virtual COM port default settings are 115.2 kBaud, 8 bits, 1 stop bit, no parity and no hardware flow control.

### NOTE:

*The SOF8\_409C windows application is included with the 409C. This program has a "COM Port" menu where you can view the available COM ports and select the COM port that is connected to your 409C. The SOF8\_409C software automatically sets your selected COM port to the 409C default COM port settings.*

**3.6 /RS232 Option Connector.** For 409C models with the /RS232 option, there is a DE9 connector with data **TO** the 409C on pin 3; data **FROM** the 409C is on pin 2 and the **COMMON** return on pin 5. A six foot 9-pin monitor extension cable is provided and allows direct connection to the 409C without a null modem or gender changer. The provided XCHIP-X USB adapter can be connected to the extension cable for connecting to a USB port.

**Table 1 Response and Error Codes**

Error Code	Meaning
OK	Good Command Received
?0	Unrecognized Command
?1	Invalid Frequency
?4	Invalid Phase
?6	Invalid Parameter
?7	Invalid Amplitude
?8	Invalid Baud Rate
?A	Invalid Amplitude
?C	Invalid Channel Number
?D	Invalid Dwell Time
?E	Empty Row in Active Range
?F	Invalid Frequency
?M	Invalid Parameter
?N	Invalid Table Row Number
?P	Invalid Phase
?R	Table is Running
?S	Invalid when Sweep is Enabled
?T	Invalid Table Command
?V	Invalid Calibration Value
?W	Invalid Active Row Range

**3.7 Serial Commands.** Commands are not case sensitive and must end with any combination of Carriage Return (CR), Line Feed (LF) or CRLF. A response code is returned after sending a command. See Table 1 for a list of the response codes and Tables 2, 3 and 4 for a list of the serial commands.

**3.8 Query Command.** The **Q** command returns the present state of the 409C non-volatile parameters. See Tables 2 and 3 for a description of each of the parameters. An example of the data returned by the Q command is as follows:

**Example Response to 'q' Command**

```

q
Operating mode: 409C
F0=60.000000 P0=0.00 V0=1.000
SWEF0=150.000000
SWRSF0=1.000000 SWFSF0=1.000000
SWRST0=1.000 SWFST0=1.000
SWMD0=S SWENB0=D

F1=10.000000 P1=0.00 V1=1.000
SWEF1=150.000000
SWRSF1=1.000000 SWFSF1=1.000000
SWRST1=1.000 SWFST1=1.000
SWMD1=S SWENB1=D

F2=10.000000 P2=0.00 V2=1.000
SWEF2=150.000000
SWRSF2=1.000000 SWFSF2=1.000000
SWRST2=1.000 SWFST2=1.000
SWMD2=S SWENB2=D

F3=12.000000 P3=0.00 V3=1.000
SWEF3=150.000000
SWRSF3=1.000000 SWFSF3=1.000000
SWRST3=1.000 SWFST3=1.000
SWMD3=S SWENB3=D

Clock mode: I
FR 10.000000 MHz
FD 400.000000 MHz
Synthesis clock: 460.800000 MHz
VS=1 M=N I=A TSCALE=1
TRNG=00000 - 14249
TS input: Disabled
IOUD mode: Output
Firmware version: 1.6
OK
    
```

**Table 2: Serial Commands** (Not Case Sensitive)

<b>Serial Command</b>	<b>Function</b>
Fn xxx.xxxxxxx	Set <b>Frequency</b> of output ‘n’ in MHz to nearest 0.1Hz. n=0, 1, 2 or 3. Decimal point not required. 0.00 sets a channel to DC. Maximum setting: 171.1276031 MHz. Single tone mode.
Fd xxx.xxxxxxx	Stores the <b>External Direct Input</b> frequency in MHz. Used with the ‘C d’ command. Valid entries are 1.000000 to 500.000000.
Fr xxx.xxxxxxx	Stores the <b>External Reference Input</b> frequency in MHz. Used with ‘C e’ command. Valid entries are 10.000000 to 125.000000. Entries below 22MHz may require external filters.
Pn xxx.xx	Set <b>Relative Phase</b> of output ‘n’ in degrees. n=0,1,2 or 3. xxx.xx = 0.00 to 359.99. Single tone mode.
Vn x.xxx	Set the <b>Amplitude</b> of output channel ‘n’. n=0,1,2 or 3. The amplitude indicates the signal level in Vpp when driving a 50 ohm load. Maximum amplitude setting is x = 1.000 (the default) . If the amplitude scale factor is not 1, the Vn command specifies the output amplitude before the amplitude scale factor is applied. Does not work when sweep is enabled.
Vs n	Set the output <b>Amplitude Scale Factor</b> . n=1 for full scale, n=2 for one half scale, n=4 for one quarter scale and n=8 for one eighth scale. All channels are scaled equally
E x (E d & E e)	Serial <b>Echo</b> control. x=d for Echo Disable, x=e for Echo Enable
R	<b>Reset</b> . This command resets the 409C to the same state as after power-up or cycling power, except the baud rate remains unchanged (cycling power will reset the baud rate to 115.2KBaud).
CLR	<b>Clear</b> . This command resets all factory default values except for the values stored in table memory. Use the <b>TCLEAR</b> command to reset the table to an empty state.
S	<b>Save</b> . Saves Frequency, Amplitude, Amplitude Scale Factor, Phase, Phase Reset Mode, Update Mode, Active Table Range, Table Dwell Scaling and Echo settings to flash memory. Does not save the Table Rows. Use TSAVE to save Table Rows. Saved values will be recalled after power up or reset. Use the ‘CLR’ command to return to factory default values.
Q	Returns the current values of the 409C settings and the firmware version.
C x (C i, C e, C d & C r)	<b>Set Clock Source</b> . Set x= i for internal clock. Set x=e for external reference. Set x=d for direct input. Set x=r for lock to 10MHz (x=r available only when /R option is installed) See Table 5 for details on these settings.
M x (M n, M a, M s)	<b>Phase Mode</b> . x=n means the phase will not be reset with every update. This is the default mode. x=a means the phase will be reset on every update. x=s will force a manual update on all phases.
I x (I a, I m, I p, I e, I s & I d)	<b>I/O Update (IOUD &amp; TS)</b> . If x=a, then an IOUD update pulse is automatically sent at the end of each serial command. This is the IOUD default. Sending ‘I x’ with x=m, puts IOUD into manual mode and an update pulse must be sent manually. This manual IOUD update pulse happens by sending the ‘I x’ command with x=p. If x= e, then the IOUD is changed from an output to an input requiring an external logic pulse to cause an update. If x=s, then external TS inputs are enabled and serial commands are disabled. If x=d the external TS inputs are disabled (I d is the default TS condition) and serial commands are enabled.
B aa[bb[cc[dd[ee[ff [gg]]]]]]	This <b>Byte</b> command allows each register in the DDS chip to be set. Different registers require a various number of bytes to be written depending upon the function. Please consult Analog Devices AD9959 data sheet for details. Note that it is possible to set the DDS chip into a non-functional mode, requiring a power cycle to recover. All values are in hexadecimal and no error checking, other than correct format, is performed.

**Table 3: Serial Commands For Frequency Sweeping**

(Not Case Sensitive)

Command	Function
SWENBn x	<b>Enable Sweeping.</b> n = Output channel number, x = E for enable or x = D for disable
SWMDn x	<b>Sweep Mode.</b> n = Output channel number, x = S sets single ramp up step down, x = D sets dual ramp up and ramp down.
SWEFn xxx.xxxxxxx	<b>Ending Frequency.</b> n = Output channel number, xxx.xxxxxxx = Ending frequency in MHz. (Beginning frequency is set by the Fn xxx.xxxxxxx command)
SWRSFn xxx.xxxxxxx	<b>Rising Frequency Step Size.</b> n = Output channel number, xxx.xxxxxxx = Frequency step size in MHz
SWFSFn xxx.xxxxxxx	<b>Falling Frequency Step Size.</b> n = Output channel number, xxx.xxxxxxx = Frequency step size in MHz
SWRSTn t	<b>Rising Time Step Size.</b> n = Output channel number, t = Step size in Microseconds
SWFSTn t	<b>Falling Time Step Size.</b> n = Output channel number, t = Step size in Microseconds
PPn 0 or PPn 1	<b>Software Sweep Triggering.</b> n = Output channel number, The PPn 0 command sets trigger Low, PPn 1 sets trigger high. See paragraph 4.23 for software triggering info.
PPn x	<b>Hardware (J8) Sweep Triggering.</b> n= Output channel number, x=x sets the trigger source to a 3.3V signal on J8 pins 5,6,7 and 8. See para. 3.9.and 4.23 for hardware triggering info.

**Example of Single Sweep from 10MHz to 60MHz in 10 seconds on Channel 0**

Send the following commands: f0 10, swef0 60, swrst0 2, swrsf0 0.00001, swenb0 e, swmd0 s.

Trigger a sweep from software by sending the following commands: pp0 0 then pp0 1.

Trigger a sweep from connector J8 by sending the command pp0 x and then apply a rising 3.3 volt signal to J8 pin 5.

NOTE: Sweep time is 50MHz/10Hz per step = 5,000,000 steps times 2 μS/step = 10 seconds.

**Example of Dual Sweep from 10MHz to 60MHz to 10MHz on Channel 0**

Send the following commands: f0 10, swef0 60, swrst0 2, swfst0 2, swrsf0 0.00001, swfsf0 0.00001, swenb0 e, swmd0 d.

Trigger a sweep in software by sending the following commands: pp0 0 then pp0 1 (starts rising sweep) then send pp0 0 (starts falling sweep).

Trigger a sweep from connector J8 by sending the command pp0 x and then apply rising and falling 3.3 volt signals to J8 pin 5.

**Table 4: Serial Commands For Table** (Not Case Sensitive)

Serial Command	Table Functions (A bracket set [...] indicates optional parameters)
T r d c f p a [c f p a] [c f p a] [c f p a]	<b>T Command.</b> Enters a row into the table. Where r=row, d= dwell, c=channel, f=frequency, p=phase and a=amplitude. One channel set consisting of 'c f p a' values is required. Up to three additional channel sets as indicated by [...] is optional. The entire T command must be on one line.
TSCALE x	<b>Dwell Scaling Command.</b> 'x' can be 1 or 4. x=1 is the default and sets the maximum dwell time to 8191.875 microseconds. If x=4 then all the dwell times are multiplied by 4 and the maximum dwell time becomes (4 x 8191.875 = 32.7675) milliseconds. Parameter 'x' is saved using the 'S' command.
TSAVE	<b>Save to Flash Command.</b> The T Command creates table data in RAM memory. The TSAVE command saves this RAM table data to flash memory. The table only operates on data that is in flash memory.
D x y	<b>Display Table.</b> Reads and displays the table values from row x to row y.
TRNG x y	<b>Table Range Command.</b> Makes a range of rows in the table <b>Active</b> . The TRUN and TONCE commands only operate on the Active rows. The active rows start at row x and include all rows up to and including row y. Default is the entire table from row 0 to 14249. The parameters x and y are saved using the 'S' command.
TRUN [x y]	<b>Run Table Command.</b> Saves all table rows to flash memory if they have been entered but not saved and starts the table continuously looping through the active table rows. If the optional x and y parameters are entered then the table will loop from row x to row y. Also sets the IOUD signal to an output and disables the TS hardware inputs.
TONCE [x y]	<b>Run Table Once Command.</b> Saves all table rows that have been entered but not saved and causes the table to run once through the active table rows. If the optional x and y parameters are entered then the table will run once from row x to row y. Also sets the IOUD signal to an output and disables TS hardware inputs.
TTRIG [row row]	<b>Run Table Once Hardware Trigger.</b> After this command is run the instrument waits for a trigger input on the external interface TS pin. Each rising edge on the TS pin will cause the table to be run once. A TSTOP command is required to exit this mode. The range of table rows is specified with the TRNG command or with the optional start and ending row numbers provided with this command.
TSTOP	<b>Stops</b> the table from running. The state of the channels will be the same as they were when the table was stopped.
TS [x]	<b>Table Step Command.</b> Causes the table to move to the next active row. Does not save table data in RAM to flash memory. You must use the TSAVE command to save to RAM. If the optional 'x' parameter is included it causes the table to go to row x. <i>Requires Is and TRNG be set and Table to be stopped. See table 2.</i>
TCLEAR	<b>Clear Table Command.</b> Resets all table rows in the table flash memory to the empty state.

**3.9 Connector J8.** The rear panel J8 connector provides access to the IOUD input/output and the TS input signals and the trigger pins for the Sweep feature. The IOUD default is output mode and the TS default is disabled. IOUD output has a 1.5K series resistor to limit output current. IOUD & TS are controlled by the ‘I x’ command (see table 2) .

The pin numbers from left to right when facing the rear panel are 13, 11, 9, 7, 5, 3, 1 (top) and 14, 12, 10, 8, 6, 4, 2 (bottom). +IOUD is on pin 1 and +TS is on pin 3. Pins 5,7,9 and 11 are the sweep trigger pins for channels 0,1,2 and 3. All the other pins are connected to instrument ground. A plug compatible, six inch long, 14-pin ribbon cable is included.

The logic levels are 0V for logic 0 and 3.3V for logic 1.

**3.10 Rack Mounting.** An optional 1U rack adapter is available for mounting up to four 409C into a rack panel.

## 4.0 OPERATING INSTRUCTIONS

### 4.1 Apply Power

Plug the 5Vdc connector from the AC Power Adapter into the rear panel connector labeled 5V.

After power is applied, the 409C takes approximately 500ms to initialize. Commands sent during this time will be ignored or may cause erroneous operation. After all the power is applied and all signal cables and serial communication cables are installed and operating , send the 409C the “R” (Reset) command .

**4.2 Warmup.** Specifications are met within approximately 15 minutes of power up.

**4.3 Commands.** After the 409C has been installed in the customer application system, all that is required for operation is to send the appropriate serial commands as shown in Tables 2 and 3 on pages 5, 6 and 7.

### NOTE

*The “B” command shown in Table 2 can be used to test the AD9959 DDS chip programming as it allows access to all internal registers. While not a real-time simulation, each “B” command functions as an input by putting a data byte directly into the AD9959 via an SPI port, and*

*then pulses the IOUD line. This is similar to a procedure that a customer control circuit might perform. The “B” command values are not saved so they will not show in the Q or QUE command output. Consult the Analog Devices for support. Novatech Instruments does not provide tech support for the “B” command*

**4.4 Response Codes.** The user host computer software must properly format the serial commands. Incorrect formatting will result in a response error code being returned. See Table 1 for a list of response error codes.

**4.5 Echo.** For maximum interface speed, it is suggested that Echoing be disabled by using the “E d” command. This will allow the host to send characters at a faster rate. Even when Echo is disabled, the 409C will respond with an “OK” for a correctly received data command.

**4.6 Baud Rate.** A special command, “Kb x”, is available if you wish to set a baud rate that is different from the default of 115.2KBaud. The value set by this command is volatile and not saved in flash memory. Upon power up, reset or clear, the 409C defaults to 115.2KBaud. The available “Kb x” commands are:

KB 0 sets baud rate to 9600

KB 1 sets baud rate to 19200

KB 2 sets baud rate to 38400

KB 3 sets baud rate to 57600

KB 4 sets baud rate to 115200 (default)

KB 5 sets baud rate to 230400

KB 6 sets baud rate to 460800

**4.7 Synthesizer Clock Selection.** The 409C uses the “C x” command to select the synthesizer clock. See the top of page 9 for an explanation of the choices available using this command.

**4.8 External Filters.** The 409C provides low pass filters on all outputs to eliminate spurs and harmonics. These filters are optimized for internal clock settings. When using an External Reference (C E) or a Direct Input (C D) clock, it may be desirable for the user to provide external low pass filters.

In order to eliminate spurs and harmonics, the low pass

**Table 5 Synthesizer Clock**

Command	Clock Select Commands
C i	Selects the Internal oscillator. When the /R option is installed the internal master oscillator is the VCTCXO in the /R circuit. In C I mode the /R phase lock circuit is bypassed. When the /R option is not installed the internal master oscillator is the TCXO oscillator. (See Figure 1 on page 12.) The Synthesizer Clock is the Internal master oscillator stepped up by the AD9959 clock multiplier.
C r	<b>Only applicable when Option /R is installed (409C Firmware v2.1 and Above).</b> Selects the VCTCXO oscillator in the /R option circuit. The synthesizer clock is the VCTCXO oscillator stepped up by the AD9959 clock multiplier. The VCTCXO oscillator is disciplined by the 10MHz input when present. (This is the default when the /R option is installed). If there is no 10MHz connected then the VCTCXO oscillator in free running mode is used.
C e	Selects External Reference Clock. The Synthesizer Clock is the frequency stored by the Fr xxx.xxxxxx command stepped up by the AD9959 clock multiplier. The user must apply a signal with frequency Fr xxx.xxxxxx to the rear panel BNC connector.
C d	Selects External Direct Clock. The Synthesizer Clock is the frequency stored by the Fd xxx.xxxxxx command. The user must apply a signal with frequency Fd xxx.xxxxxx to the rear panel BNC connector (SMA connector if Option E is installed) The AD9959 multiplier is not used.

filters should have a sharp roll off at or below about 40% of the synthesizer clock frequency. When using External Reference or Direct Input clocks the user should use the “Q” command to find the synthesizer clock frequency and if it is much below 429MHz then consider using external filters at about 40% of the synthesizer clock frequency.

**4.9 Phase Alignment.** Phase relationships are maintained by appropriate use of the “M” and “I” commands. The “M” command has special modes “M a” and “M n”. “M a” means automatically clear phase at the end of each command. This will clear the phase register each time any command is performed. This is important when all outputs must be phase aligned. However, it will cause a phase jump in the output.

**4.10 Phase Synchronous.** The “M n” command turns off the automatic clearing of the phase register. This is the default mode. In this mode, the phase register is left intact when a command is performed. Use this mode if you want frequency changes to remain phase synchronous, with no phase discontinuities. The “M s” command will immediately align the phases on all outputs but will also cause a one time phase discontinuity.

**4.11 Command Execution.** Further control of phase relationships and timing of command execution can be exercised by using the “I x” commands. The default mode is automatic (x=a) in which a command is parsed and executed immediately following the end of the serial input sequence. In manual mode (x=m), an update pulse will not be sent to the DDS chip automatically. This is useful when it is important to change all the outputs to new values simultaneously. Use external triggering or the “I p” command to cause a manual update. Sending “I x” where x=e, x=s or x=d controls the function of the IOUD and TS control logic. (See Section 9)

**4.12 Amplitude Matching.** For applications which require precise amplitude matching between the channels, the recommended method is to use the “Vn x.xxx” command to adjust the channels to match.

**4.13 Table Mode.** The Model 409C contains Flash memory capable of storing up to 14249 rows of data in a table format. Each row can specify the frequency, phase and amplitude of each channel in any combination of channels. Any channels that are not specified in a row will not change when the row is run. The row also stores a dwell time that specifies how long the channel settings specified by the row are held before stepping to the next row. The dwell time is only used when running the table.

To run the table send a **TRUN [x y]** or **TONCE [x y]** command where [x,y] are optional beginning and ending row numbers. If [x,y] are omitted the entire table will run. You can also manually step through the table using the **TS [x]** command. The table mode enables you to update the 409C outputs very quickly since running the table eliminates the need to communicate over the USB port every time you send a frequency, phase and/or amplitude command.

**4.14 Dwell Time.** When running the table, one row is in dwell mode at the same time the next row is being loaded into the AD9959 registers. To allow time for this loading there is a minimum dwell time requirement that is a function of the size of the following row. This limit is as follows:

- 13 microseconds when next row has 1 channel*
- 19 microseconds when next row has 2 channels*
- 25 microseconds when next row has 3 channels*
- 31 microseconds when next row has 4 channels*

The resolution and range of the dwell time is controlled by the **TSCALE** command. **TSCALE** can be set to 1 or 4. **TSCALE = 1** is the default and sets the allowable range from the minimum above to 8191.875 microseconds. Setting **TSCALE = 4** multiplies all existing dwell times by 4 and makes the allowable range the minimum to 32.7675 milliseconds.

**4.15 Table Data Entry.** The **T** command along with the **TSAVE** command are used to enter data into the 409C Table. An example **T** command for entering one output channel is as follows:

```
T 1 100 0 10 180 0.8
```

In this example the row number is 1, the dwell time is 100 microseconds, there is one output channel setting and it is channel 0 which is set to 10MHz, 180 degrees phase and 0.8Vpp amplitude. Channels 1, 2 and 3 will not be changed. There must be a space separating each parameter and any channel included must contain frequency, phase and amplitude values. All **T** commands must be on a single line and end with a carriage return line feed. **T** commands store the data in RAM. The row data must be in Flash memory to operate as a table. The **TSAVE** command, the **TRUN [x y]** command and the

**TONCE [x y]** command will each move any rows that are in RAM memory to table flash memory.

Another Example **T** command:

```
T 500 31 0 10 180 0.8 1 11 270 0.9 2 12 359.99 0.955 3
13 90 1
```

This example enters four output channels in row number 500 with a dwell time of 31 microseconds. Row 500 sets output channels 0,1,2 and 3 to frequencies 10,11,12 and 13MHz. The phases are set to 180, 270, 359.99 and 90 degrees and the amplitudes are set to 0.8, 0.9, 0.955 and 1vpp.

**4.16 Reading Table Values.** The **D x y** command will return the contents of the table from row x to row y. If there is no data in these rows or if some rows have no data then the **D x y** command will return “xxxx Empty Row”, where xxxx is the row number, for the rows with no data.

**4.17 Active Rows.** The **TRNG x y** command makes the table rows from row x to row y the Active Rows. The **TRUN [x y]** command with no optional [x y] parameters causes the 409C to loop through all the active rows continuously until a **TSTOP** command is received. The **TONCE [x y]** command with no optional [x y] parameters will run the active rows one time. If you send **TRUN [x y]** or **TONCE [x y]** and include the optional x and y parameters then the active rows are from row x to row y and the 409C will step through the table from x to y continuously (**TRNG**) or one time (**TONCE**).

**4.18 Single Stepping the Table.** The **TS [x]** command can be used to execute any single row in the table as designated by the x row parameter. Note that the **TS [x]** command does not move table data from RAM memory to flash table memory so you may need to use the **TSAVE** command before using the **TS [x]** command. Also, you cannot use the **TS [x]** command if the table is running. If you execute the **TS** command without including the optional x parameter, then the manual steps will start at the beginning of the active row as set by the **TRNG** command. Once you manually step to the end of the active rows, the next **TS** command will take you back to the first active row.

#### 4.19 Table Synchronization with External Events.

For precision timing application it is recommended that external table synchronization be used. This involves triggering table operations using customer supplied external hardware. See Section 9 for detailed instructions.

**4.20 Frequency Sweeping.** 409C Models with firmware version 1.6 or higher have a sweep feature that enables the user to set a begin frequency and an end frequency for each output channel (n = 0,1,2,or 3) and then perform one of the following sweep modes:

- 1) Ramp up and Ramp down (set with command 'SWMDn D').
- 2) Ramp up and step down (set with command 'SWMDn S').

**4.21 Set Up a Sweep.** The beginning frequency is set using the 'Fn xxx.xxxxxxx' command. The ending fre-

quency must be larger than the beginning frequency and is set using the 'SWEFn xxx.xxxxxxx' command.

The frequency step size is programmable when ramping up and also when ramping down. The ramp up frequency step size is set by the 'SWRSFn xxx.xxxxxxx' command and the ramp down frequency step size is set by the 'SWFSFn xxx.xxxxxxx' command.

The time duration of each step is programmable when ramping up and also when ramping down. The step time duration when ramping up is set by the 'SWRSTn t' command and the step time duration when ramping down is set by the 'SWFSTn t' command.

The parameter 't' above can be from 0.009 microseconds to 2.2 microseconds when using the internal clock or the /R option. When using an external reference or direct clock the parameter "t" has a minimum of 4/Fs and a

### FREQUENCY SWEEP MODES

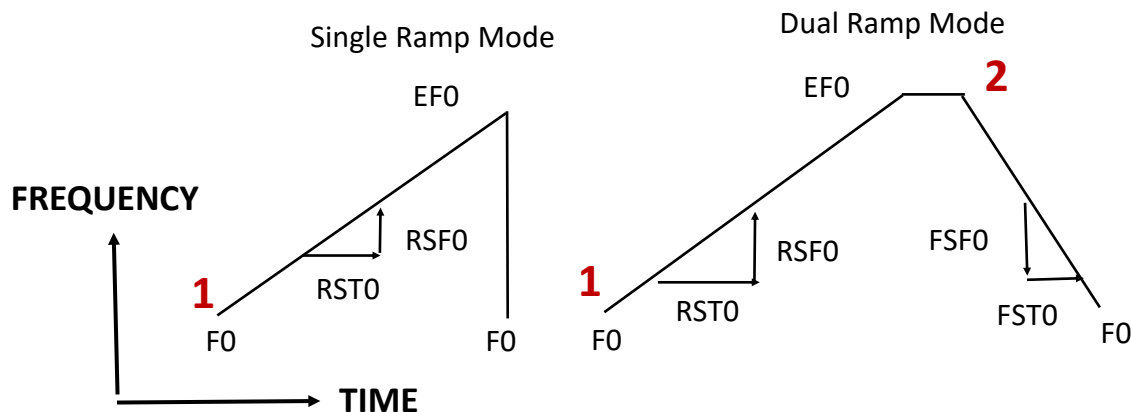

NOTE: Sweep commands start with SW. Thus, to set the rising step time of channel 0 to 1 microsecond the command would be **SWRST0 1**

#### SINGLE SWEEP MODE CHANNEL 0

#### DUAL SWEEP MODE CHANNEL 0

Point 1 shows the Trigger point to start the sweep

Point 1 shows the Trigger point to start the rising sweep

F0 Beginning & Ending Frequency

Point 2 shows the trigger point to start the falling sweep

RST0 Rising Step Time

F0 Beginning & Ending Frequency

RSF0 Rising Step Frequency

RST0 Rising Step Time

EF0 End of Rising Frequency

RSF0 Rising Step Frequency

EF0 End of Rising Frequency

FSF0 Falling Step Time

FST0 Falling Step Frequency Channel 0

maximum of  $1020/F_s$  where  $F_s$  is the Synthesis Clock frequency as displayed with the 'q' command.

**NOTE:**

*Entering a step time  $t$  that is larger than the maximum allowed value for  $t$  will result in the step time being set to the maximum allowed value.*

**4.22 Total Sweep Time.** To compute the total time a sweep will take, first compute the total number of steps. This is the begin frequency minus the end frequency divided by the frequency step size. The sweep time will then be the number of steps times the step time.

**4.23 Running a Sweep.** To execute a sweep the user must first enable sweeps using the 'SWENBN x' command where x can be E for enabled and D for disabled. Once enabled the sweep must be triggered with a rising edge on the trigger input to start a rising sweep and, when in Dual Mode, a falling edge to start a falling sweep. Triggering is done in software by using the 'PPn 0' and 'PPn 1' commands. Triggering is done with hardware by sending the 'PPn x' command and applying 3.3V signal transitions. See example on page 6.

**4.24 Sweep Default Settings.** The default sweep settings for output channel 0 are as follows:

F0=10.0000000 P0=0.00 V0=1.000  
(Begin frequency = 10MHz, Phase = 0, Vout = 1Vpp)

SWEF0=150.0000000  
(Ending frequency = 150MHz)

SWRSF0=1.0000000 SWFSF0=1.0000000  
(Rising and falling frequency steps = 1 MHz)

SWRST0=1.000 SWFST0=1.000  
(Rising and falling time steps = 1 microsecond)

SWMD0=S SWENB0=D  
(Sweep mode set to Ramp up and Step down. Sweep Enable/Disable set to Disable)

**4.25 Sending Sweep Commands.** It is recommended that the SOF8\_409 software command menu be used to set the sweep parameters and run the sweep. Sending a 'q' command will display the current settings of the sweep parameters on all output channels.

**5.0 THEORY OF OPERATION**

**5.1 Block Diagram.** Please refer to the simplified System Block Diagram below for the following discussion.

**5.2 DDS.** At every cycle of the 409C system clock, the AD9959 integrated circuit increments the phase of an internal register by a value calculated from the frequency command and sent to the AD9959 by the microcontroller. The AD9959 converts this phase value to a sinusoidal amplitude level and then sets the values of on-chip

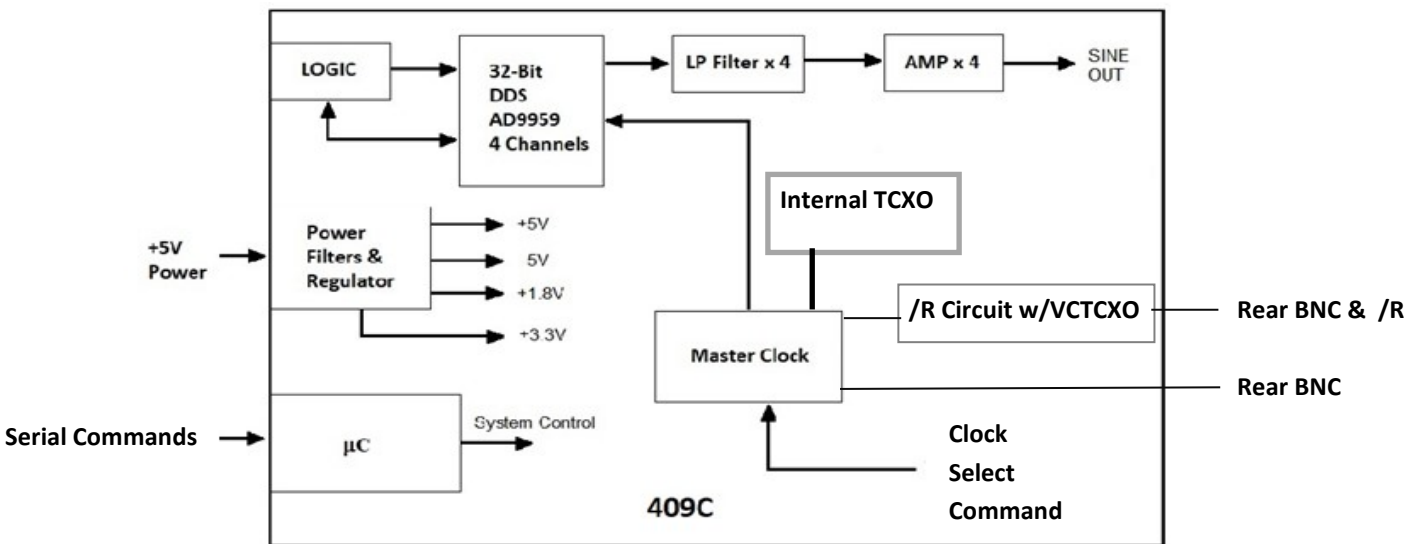

Note: Master Clock is the synthesizer clock prior to applying the AD9959 clock multiplier

Figure 1  
Simplified System Block Diagram

**Table 6: Recommended Test Equipment**

Item	Minimum Specification	Recommended
Oscilloscope	300 MHz 50Ω	Tektronix TDS3032B
50 Termination	50Ω ±1%	Tektronix 011-0049-01 or
Frequency Counter	180 MHz	HP53132A
Counter Time Base	10 MHz <±0.1 ppm	Novatech Instruments Model 2960AR
External Clock	400 MHz	Novatech Instruments Model 440A

**Table 7: Frequency Test Points**

Frequency	Tolerance
100 kHz	± 0.15 Hz ±1 LSD + 0.1Hz /yr
10 MHz	±15 Hz ±1 LSD + 10Hz/yr
100 MHz	±150 Hz ±1 LSD + 100Hz/yr

10-bit digital-to-analog converters. The analog signals from these converters are filtered by differential 7th-order elliptical low pass filters, amplified and sent to the 409C output connectors.

**5.3 Maximum Frequency.** The 409C theoretical output frequency is limited to a maximum of 1/2 the system clock frequency. While it is possible to generate an output near 50% of the system clock, the distortion would be unacceptable. For this reason, the 409C frequency output is limited to 171MHz by 7th-order elliptical low pass analog filters on all four output channels.

**5.4 External Filters.** External filters are NOT needed when using the TCXO internal clock or the VCTCXO clock in the /R option circuit. However, if you are using an external reference ('C e') or direct clock ('C d') you may need an external filter on the 409C outputs. For best performance, use very high rolloff filters and set the corner frequency of the filters at 40% or less of your synthesizer clock frequency. The synthesizer clock frequency can be displayed by sending the "q" command after having entered the Fr or Fd parameters and sending the 'C e' or 'C d' command.

## 6.0 PERFORMANCE TEST

**6.1 Setup.** Install the 409C as directed in the Serial Operation part of Section 3. Connect your host controller and operate the 409C per Section 4. The test limits assume a stable environment of 18-28°C.

### NOTE:

*Allow the 409C to warm up for at least 15 minutes before performing any measurements. For best results, the 409C should be verified in its installed environment.*

**6.2 Test Equipment.** See Table 6 for a list of recommended test equipment to perform the following measurements.

**6.3 Verify Frequency Accuracy.** Remove all external clock connections and set clock to internal clock ('C i'). Set the output sequentially to each value in Table 7. Connect the recommended frequency counter set to 50Ω termination and 1 Hz resolution. Verify the limits shown in Table 7. Test all channels to verify functionality of all outputs. Be sure to add the error of your counter to the frequency tolerance.

**6.4 Sine Out Amplitude Verification.** Set the frequency of the 409C to 10 MHz. Connect the 409C to the oscilloscope set for 50Ω termination. Set the oscilloscope to measure amplitude using at least 16 averages. Verify a reading of 1Vpp ±0.25Vpp (4dBm ± 3dBm). Repeat for the other outputs.

**6.5 Amplitude Level Test.** Set the output frequency to 10 MHz. Send the command "Vn 0.5" to each channel, where "n" is your channel number being tested. Verify that the amplitude on each channel decreases by one-half.

Send the “R” command to reset the levels before performing the next tests.

**6.6 Output Flatness Verification.** Verify that the outputs are flat with frequency by performing the following test: Connect the 409C to the oscilloscope set for 50Ω termination. Set the output frequency of channel 0 to 35MHz and note the output amplitude.

**6.7** Set the output of channel 0 to the values of 100kHz and 100MHz and verify that the amplitude reading remains within ±3dB (x1.414 to x0.707 Vpp) of the 35MHz.value noted in the previous paragraph.

**6.8** Repeat the output flatness verification test for each output channel.

**6.9 External Clock Direct Input Verification.** Connect a 400 MHz external clock source via a short coaxial cable to the BNC on the rear panel. Send the command Fd 400 then Send the command “C d” to select the external direct clock input. Set the frequency output of Channel 0 to 10.000 MHz.

**6.10** Verify Channel 0 has an output of 10MHz. You must account for any frequency errors in your external 400MHz clock.

**6.11 External Clock Reference Input Verification.** Connect a 25MHz Signal to BNC on the rear panel. Send a ‘FR 25’ command and a ‘C e’ command. Set the frequency of output channel 0 to 10MHz.

**6.12** Verify Channel 0 has an output of 10MHz. You must account for any frequency errors in your external 25MHz clock.

**6.13 Option /R Verification.** Perform this step if the 409C has Option /R installed. Connect a 10MHz Signal to the BNC on the rear panel. Send a ‘C r’ command. Verify that the front panel LED blinks green rapidly for about 15 seconds and then turns solid green. Set the frequency of channel 0 to 10MHz.

**6.12** Verify Channel 0 has an output of 10MHz. The accuracy of channel 0 should be the same as the accuracy of the external 10MHz clock input.

**6.11** Return the 409C to normal operation and default values by sending the “CLR” command.

## 7.0 CALIBRATION

**7.1** The full scale output amplitude is adjustable using the “ZCal0 x” command. Where x is an integer from 0 to 127. x = 0 sets the output to the maximum value, x = 127 sets the output to the minimum value. Send “ZCal9” to save the setting. “ZCal0 127” is the factory default. No other calibrations are available.

## 8.0 OPTION /R: LOCK TO 10MHz REFERENCE

**8.1** The /R option provides locking and tracking circuitry to phase lock the internal VCTCXO master oscillator to an external 10MHz reference.

### NOTE:

*409C with firmware 2.0 and above requires the active clock source command to be set to ‘C r’. This is the factory default value when /R is installed.*

**8.2** A 10MHz reference must be connected to the rear panel BNC connector labeled 10MHz input. See paragraph 2.5 for the required specs of this signal. The 10MHz input signal is automatically detected and, if within a lock range of approximately ±5ppm, it is locked to and tracked by a narrow-band phase lock loop.

**8.3** If an input signal is not detected, the unit will default to using the VCTCXO master oscillator in free-running mode.

**8.4** The front panel LED will display four conditions:

**Steady Green:** The 409C is locked to and is tracking a stable external 10 MHz reference.

**Blinking Green:** The 409C is trying to lock to an external 10 MHz (fast blinking) or there is no external 10MHz input (slower blinking). When blinking green the 409C is using the free running VCTCXO master oscillator.

**Steady Red:** The 409C detects an external input, but cannot lock to it. The 409C is not using the free running VCTCXO oscillator and master the output frequency is in an unknown state.

**8.5** When changing the reference mode, the phase lock loop may take several minutes to stabilize to the final resolution of the 409C. Changing from a blinking LED to a stable LED indicates that the process is completing, but you should verify the outputs.

## 9.0 OPTION – AC EXTERNAL TIMING CONTROL

**9.1 Description.** Option –AC adds two rear mounted SMA connectors, labeled IOUD and TS, that can be used for triggering and synchronizing 409C outputs. These signals are in parallel with the IOUD and TS pins on the rear mounted header connector J8. The logic levels for these pins are 0V for logic 0 and 3.3V for logic 1.

**9.2 IOUD Output vs Input.** By default, the IOUD signal is an output indicating that the microcontroller has triggered an update. The “I e” command changes IOUD from an output to an input and requires that an external trigger pulse IOUD high to update the 409C outputs.

**9.3 IOUD Used as Output.** The IOUD signal is pulled down internally to ground. When the 409C microcontroller updates the 409C, it pulses IOUD high. The actual trigger happens on the rising edge of this signal and this rising edge can be read by the users hardware.

**9.4 TS Input.** The TS input connector is disabled by default. It can be enabled using the IS command. When enabled it functions just like the “TS” serial command. If a table is not running and the TS input is enabled, then applying a trigger signal to the TS connector will step through the active rows of the table. The TS input is pulled down inside the 409C. Pulsing the TS input high, will trigger the update on the positive edge of the pulse. An edge occurring sooner than the minimum dwell time will be ignored.

**9.5 External Triggering when IOUD is an Input.** The AD9959 DDS ASIC must be preloaded with a new set of values prior to applying an external IOUD trigger. Preloading is done with the TS command or by applying a trigger signal to the TS connector. Once preloaded, the 409C can be triggered to update all outputs by applying a trigger pulse to the IOUD connector. The trigger signal must pulse IOUD high, the update will happen on the rising edge.

**9.6 More Precise Timing with External Triggering.** Using external triggering enables the user to take control of exactly when the outputs are updated. This avoids the uncertainty regarding the exact amount of time the processor will take to move data from Table Flash to the AD9959 DDS ASIC registers. While the user must still allow upwards of 10 microseconds for this data to move, the timing of the trigger update is decoupled from this time uncertainty. Thus, this method enables the user to more easily synchronize updates with external events. External triggering can be used with the table and it can also be used without the table when the user is sending serial commands.

### 409C Rear Panel



#### Note

*The rear panel BNC connector may be labeled 10MHz IN for use with the /R option but it can also accept External Reference and Direct Input clock signals at frequencies above 10MHz.*

## **WARRANTY**

NOVATECH INSTRUMENTS warrants that all instruments it manufactures are free from defects in material and workmanship and agrees to replace or repair any instrument found defective during a period of one year from date of shipment to original purchaser. This warranty is limited to replacing or repairing defective instruments that have been returned by purchaser, at the purchaser's expense, to NOVATECH INSTRUMENTS and that have not been subjected to misuse, neglect, improper installation, repair alteration or accident. NOVATECH INSTRUMENTS shall have the sole right to final determination regarding the existence and cause of a defect.

This warranty is in lieu of any other warranty, either expressed or implied, including but not limited to any warranty of merchantability or fitness for a particular purpose. In no event shall seller be liable for collateral or consequential damages. Some states do not allow limitations or exclusion of consequential damages so this limitation may not apply to you.

All instruments manufactured by NOVATECH INSTRUMENTS should be inspected as soon as they are received by the purchaser. If an instrument is damaged in shipment the purchaser should immediately file a claim with the transportation company. Any instrument returned to NOVATECH INSTRUMENTS should be shipped in its original shipping container or other rigid container and supported with adequate shock absorbing material.

This warranty constitutes the full understanding between NOVATECH INSTRUMENTS and the purchaser and no agreement extending or modifying it will be binding on NOVATECH INSTRUMENTS unless made in writing and signed by an authorized official of NOVATECH INSTRUMENTS.

### **NOVATECH INSTRUMENTS**

United States of America

206.301.8986 Voice

<http://www.novatechsales.com/>  
sales@novatechsales.com